

# DC to AC Power inverter manual

E-1500

## Remote Control

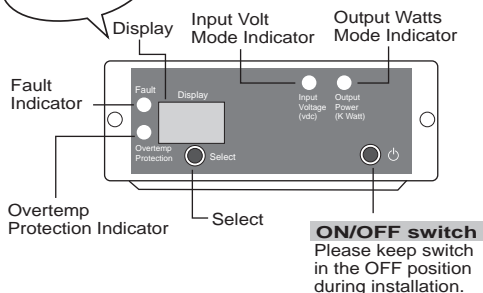

## Front view

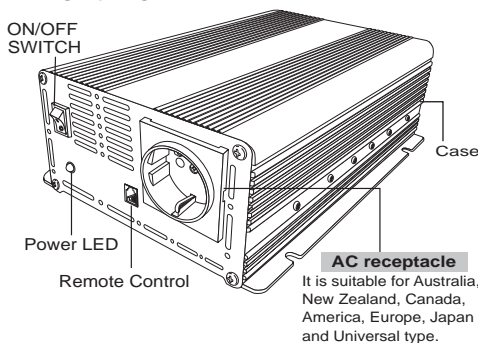

Firstly, thank you for purchase our product. Please read this manual carefully before installing or using this product.

## Specification

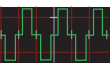
Model No.	HT-E-1500-12	HT-E-1500-24
AC Output Voltage	AC100V AC120V AC230V	
Input low voltage alarm	DC10.5V±0.5V	DC21V±1V
Input low voltage shut-down	DC10V±0.5V	DC20V±1V
Input high voltage shut-down	DC16V±0.5V	DC32V±1V
Output power continuous	1500W	
Output Frequency	50/60Hz ±3%	
Efficiency	>85%	
No load current draw	0.4 A(12V)	0.2 A(24V)
Dimensions (LxWxH)(by mm)	395*179*82.5	
Net weight (by Kgs)	3.4	
Output wave	Modified Sine Wave 	
Regulation	±8%	
Over Temperature protection	55°C ±5°C	
Cooling fan	YES	
Output reverse protection	YES	
Overload protection	YES	

## Introduction

The power inverter series are the member of the most advanced line of mobile AC power systems available.

This model is used in a wide range of application including remote homes, RVs, sailboats and powerboats. It will operate most televisions and VTR's, personal computers, small appliances and tools such as drills, sanders, grinders, mixers and blenders.

To get the most out of the power inverter, it must be installed and used properly. Please read the instructions in this manual before installing and using this model.

## Name and Main function

### 1. Front view

#### a. ON/OFF switch:

Leave in the OFF position during installation.

### b. AC outlet:

Outlet sockets available:

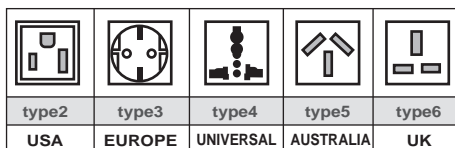

### 2. Remote Control:

#### a. Over temp protection:

LED sparkles when product temperature gets high, it would shut down automatically while temperature arrives 55±5°C.

#### b. Overload protection indicator:

Orange LED lights when inverter shut down due to overloading. Inverter would re-start twice, if failed, inverter would shut down. Please turn inverter OFF, reduce load and turn inverter ON to reset.

#### c. Digital display of remote control:

Display under battery voltage mode and load watts (Kw unit) mode, you can select the mode as your demand.

#### d. Fault Indicator :

When the below status occur, and Display shows the below words--  
HVP: high voltage protection.  
LVP: low voltage protection.  
OLP: over load protection or short circuit protection.

#### e. Display:

shows different status as point d, and modes (input voltage and output watts).

#### f. Select:

Input voltage mode and output watts (KW) selector.

#### g. Input Volt Mode Indicator.

#### h. Output Watts (K Watt) Mode Indicator.

### 3. Rear view:

#### a. Ventilation window:

Do not obstruct, allow at least 15cm for airflow.

#### b. Battery terminals:

Connect to 12V/24V battery or other 12V/24V power source. "+" is positive, "-" is negative. Reverse polarity connection will blow internal fuse and may damage inverter permanently.

#### c. Chassis ground lug:

Connect to earth ground or to vehicle chassis.



### WARNING!!

Operation of the inverter without a proper ground connection may result in an electrical safety hazard.

## Quick hook - up and testing

If you would like to quick hook-up the power inverter and check its performance before going ahead with your installation, please follow these guideline

1. Unpack and inspect the power inverter, check to see that the power switch in the OFF position.
2. Connect the cables to the power input terminals on the rear panel of power inverter. The red terminal is positive (+) and black terminal is negative (-). Connect the cables into the terminals and tighten the wing nut to clamp the wires securely.
3. Connect the cable from the negative terminal of the inverter to the negative terminal of the power source. Make a secure connection.

### CAUTION!!

Loosely tightened connectors result in excessive drop and may cause overheated wires and melted insulation.

4. Before proceed further, carefully check if the terminals connect correctly.

### CAUTION!!

Reverse polarity connection will blow a fuse in inverter and may permanently damage the inverter. **Damage caused by reverse polarity connection is not covered by our warranty.**

5. Connect the cable from the positive terminal of inverter to the positive terminal of the power source. Make secure connection.

### WARNING!!

You may observe a spark when you make this connection since current may flow to charge capacitors in the power inverter. Do not make this connection in the presence of flammable fumes, explosions or fire may result.

6. Set power inverter switch to OFF position, the indicator lights may blink and the internal alarm may sound momentarily. This is normal. Plug the test load into the AC receptacle on the front panel of the inverter. Leave the test load switch off.

7. Set power inverter switch to the ON position and turn the test load on, the inverter should supply power to the load.

## Installation

### 1. Where to install

The power inverter should be installed in a location that meets the following requirements:

- a. **Dry** - Do not allow water to drip or splash on the inverter.
- b. **Cool** - Ambient air temperature should be between -15°C and 45°C, the cooler environment is better.
- c. **Ventilated** - Allow at least 15cm of clearance around the inverter for airflow. Ensure the ventilation openings on the rear and bottom of the unit are not obstructed.
- d. **Safe** - Do not install the inverter in the same compartment as batteries or in any compartment capable of storing flammable liquids such as gasoline.

## 2. Cables

DC to AC inverters requires high amperage/low voltage DC power to low amperage/high voltage AC power. To operate properly connect inverter DC input terminals direct to battery with heaviest wire available see chart below:

Max Watts Out	Approx. Amps	Req'd Wire Gauge
100W	10A	#16
150W	15A	#16
300W	30A	#12
600W	60A	#6 or 2 X #10
1000W	100A	#4
1200W	120A	#4
1500W	150A	#4
1800W	180A	2 X #4
2500W	250A	2 X #4

## 3. Grounding

The power inverter has a lug on the rear panel "chassis ground". This is to connect the chassis of the power inverter to the ground. The ground terminals in the AC outlets on the front panel of the inverter are also connected to the ground lug. The chassis ground lug must be connected to a grounding point, which will vary depending on where the power inverter is installed. In a vehicle, connect the chassis ground to the chassis of the vehicle. In a boat, connect to the boat's grounding systems. In a fixed location, connect the chassis ground lug to earth.

The neutral (common) conductor of the power inverter AC output circuit is connected to the chassis ground. Therefore, when the chassis is connected to ground, the neutral conductor will also be grounded. This conforms to national electrical code requirements that separately derived AC sources (such as inverters and generators) have their neutral tied to ground in the same way that the neutral conductor from the utility line is tied to ground at AC breaker panel.



### Caution!!

The negative DC input of the power inverter is connected to the chassis. Do not install the power inverter in a positive ground DC system. A positive ground DC system has the positive terminal of the battery connected to the chassis of the vehicle or to the grounding point.



### Warning!!

Do not operate the power inverter without connecting it to ground. Electrical shock hazard may result.

## Operation

To operate the power inverter, turn it on using the ON/OFF switch on the front panel. The power inverter is now ready to deliver AC power to your loads. If you are operating several loads from the power inverter, turn them on separately after the inverter has been turned on. This will ensure that the power inverter does not have to deliver the starting currents for all the loads at once.

## Remote Control:

The ON/OFF switch turns the control circuit in the power inverter on and off. When the switch is in the OFF position, the power inverter draws no current from battery. When the switch is in the ON position but with no load, the power inverter draws less than 600mA (12V version) or 300 mA (24V version) from battery.

## 1. Battery voltage indicator (under input voltage mode)

The battery voltage displays the voltage at the input terminals of the power inverter. At low input current, this voltage is very close to the battery voltage. At high input current, this voltage will be lower than the battery voltage because of the voltage drop across the cable and connections. Ideally, the voltage should remain between 11V to 16V. If the voltage goes down to 10.5V (for 12V spec.) or 21.0V (for 24V spec.), inverter may shutdown.

## 2. Load indicator (under output power mode)

Displays the load watts in KW unit, i.e. if your load spec. is 1200W, the display would show you 1.2(KW).

## 3. Overtemp indicator

The overtemp indicator indicates that the power inverter has shut itself down, because it is overheated. The power inverter may overheat because it has been operated at power levels above its rating, or because it has been installed in a location where does not allow it to dissipate heat properly.

Please turn on the inverter again when it cools down.

## 4. Overload indicator (OLP)

The overload indicator indicates that the power inverter has shut itself down because its output circuit or drastically overloaded.

Turn off the inverter, correct the fault condition or reduce load, then turn on the inverter and try again.

## Operating limits

### 1. Input voltage

The power inverter will operate from input voltage ranging 10.5V-16V (12V spec.) or 21V - 32V (24V spec). If the voltage drops below 10.5V (12V spec.) or 21.0V (24V spec.), an audible low battery warning will sound, and digital display shows LVP.

The power inverter will also shut down if the input voltages exceed 16V (12V spec.) or 32V (24V spec). If the voltage are shut down because of high input volt protection, an audible high battery warning will sound, and display would shows HVP.

※ The error of above spec is  $\pm 0.5V$  (for 12V),  $\pm 1.0V$  (for 24V)

## Troubleshooting

### 1. Common problems

#### a. Buzz in audio systems:

Some inexpensive stereo systems and "boom boxes" will emit a buzzing noise from their loud speakers when operated from the power inverter. This is because the power supply in the device does not adequately filter the modified sine wave produced by the power inverter. The only solution is to use a sound system that incorporates a higher quality power supply.

#### b. Television interference:

Operation of the power inverter can interfere with television reception on some channels. If this situation occurs, the following steps may help to alleviate the problem.

-Make sure that the chassis ground lug on the back of the power inverter is solidly connected to the ground system of your vehicle, boat or home.

-Do not operate high power loads with the power inverter while watching television.

-Make sure that the antenna feeding your television provides an adequate ("snow free") signal and that you are using good quality cable between the antenna and the television.

-Move the television as far away from the power inverter as possible.

-Keep the cables between the battery and the power inverter as short as possible and twist them together with about 2 to 3 twists per foot. This minimizes radiated interference from the cables.

## 2. Troubleshooting guide

Problem	possible cause	solution
No Output voltage	1. Make sure that inverter cable connects to battery well	1. Re-set the cable
No voltage indicator	2. Internal fuse blown out	2. Change new fuse
Inverter shuts down and overload light shows	Overload	Reduce load
Inverter shuts down and overtemp light shows	Overtemperature	Improve ventilation reduce inverter temperature or let it cool down naturally
Low battery alarm	Battery volt is low	Charge battery

## Maintenance

Very little maintenance is required to keep your inverter operating properly. You should clean the exterior of the unit periodically to prevent accumulation of dust and dirt. At the same time, tighten the screws on the DC input terminals.

## Warranty

We offer 12 months warranty from the date of purchase and will repair or replace any defective power Inverter, this limited warranty is void if the unit is abused, modified, installed improperly, if the housing has been removed, if the serial number is missing, or if the original identification markings have been defaced, altered, or removed. The supplier is not liable for any incidental, consequential or other damages arising from the use, cost of removal, installation, or troubleshooting of the customer's electrical systems.

This is only warranty and the company makes no other warranties, express or implied, including warranties of merchantability and fitness for a particular purpose.

Repair or replacement are your sole remedies and shall not be liable for damages, whether direct, incidental, special or consequential, even though cause by negligence or other fault.

## Rear view

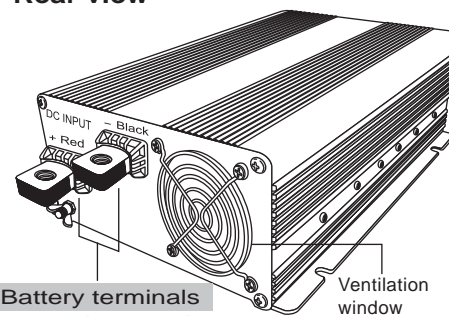

**Battery terminals**  
Connect to battery or other power source.  
" +" is positive (Red),  
" - " is negative (Black).  
Reverse polarity connection will blow internal fuse and may damage inverter permanently.