

# Battery Charger (for lead-acid battery)

## Important Safety Instructions

### **⚠ WARNING Shock and Energy Hazards**

Be sure to read the safety guidelines and pay attention to all cautions and warnings throughout the installation procedure. The installer is responsible for ensuring compliance with the installation codes for your particular application. Disconnect all sources of AC and DC power before proceeding.

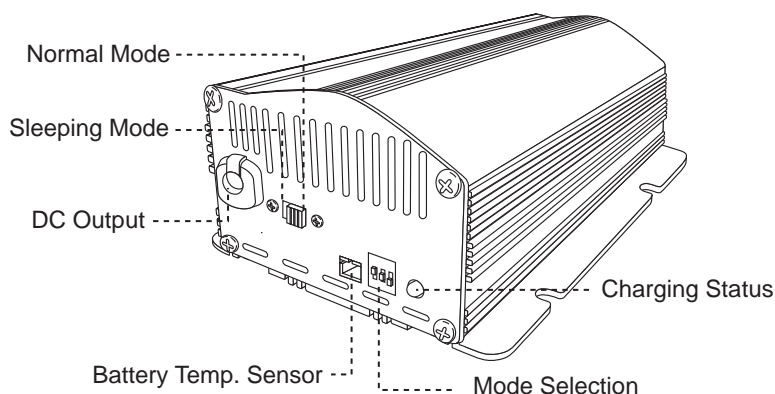

Model	HT-C-15L-230-12							HT-C-7L-230-24						
<b>INPUT</b>														
Voltage range	180 ~ 264VAC													
Frequency range	45 ~ 65Hz													
Efficiency	≥85%							≥88%						
Power factor	0.6 (230VAC) at full load (±5%)													
Input socket	IEC plug													
<b>OUTPUT</b>														
Mode Selection	Mode 1	Mode 2	Mode 3	Mode 4	Mode 5	Mode 6	Mode 7	Mode 1	Mode 2	Mode 3	Mode 4	Mode 5	Mode 6	Mode 7
Standby	14.7V, 1A	14.1V, 1A	14.1V, 1A	14.1V, 1A	15.3V, 1A	12.2V, 15A	13.5V, 15A	29.4V, 0.5A	28.2V, 0.5A	28.2V, 0.5A	28.2V, 0.5A	30.6V, 0.5A	24.5V, 7A	27V, 7A
Bulk Stage	15.3V, 15A			14.1V, 1A	15.3V, 1A	12.2V, 15A	13.5V, 15A	30.6V, 7A			28.2V, 0.5A	30.6V, 0.5A	24.5V, 7A	27V, 7A
Absorption stage (I)	14.7V, 15A-0A	14.1V, 15A-0A	14.1V, 15A-0A	14.1V, 1A-0A	15.3V, 1A-0A	12.2V, 15A	13.5V, 15A	29.4V, 7A-0A	28.2V, 7A-0A	28.2V, 7A-0A	28.2V, 0.5A-0A	30.6V, 1A-0.5A	24.5V, 7A	27V, 7A
Absorption stage (II)	/	/	15.3V, 1A max	/	/	/	/	/	/	30.6V, 1A max	/	/	/	/
Float stage	13.5V, 1A max					12.2V, 15A	13.5V, 15A	27V, 0.5A max					24.5V, 7A	27V, 7A
Max. current output	15A							7A						
Continuous current output	15A							7A						
Recommended battery capacity	45 ~ 150Ah (12V)							/	30 ~ 90Ah (24V)					/
Leakage current from battery	<1mA							/	<1mA					/
Sleeping Mode Function	YES (1/3 current output only)							/	YES (1/3 current output only)					/
<b>PROTECTION</b>														
Over temperature	55°C±5°C													
Input terminal reverse	By fuse													
Overload	YES													
Output short circuit	YES													
Microprocessor check	YES													
<b>ENVIRONMENT</b>														
WORKING TEMP.	-15°C ~ +45°C													
WORKING HUMIDITY	20 ~ 90% RH non-condensing													
STORAGE TEMP., HUMIDITY	-30°C ~ +70°C (-22°F ~ +158°F) , 10 ~ 95% RH													
TEMP. COEFFICIENT	±0.05%/°C (0 ~ 50°C)													
<b>SIZE</b>														
Dimension (L x W x H)	232 x 122 x 65mm													
Weight	1.4kgs													

\*\*The above spec. is +/-0.5V for 12V spec.; +/-1.0V for 24V spec.; Amp +/-10%.

**⚠ Note:** Specifications subject to change without notice.

- Do not expose the charger to rain, snow, spray, or bilge water. To reduce risk of fire hazard, do not cover or obstruct the ventilation openings. Do not install the charger in a zero-clearance compartment. Overheating may result.
- The charger is designed to be permanently connected to your AC and DC electrical systems.
- Before using the charger, read all instructions and cautionary markings on the charger, the batteries, and all appropriate sections of this guide.
- Use only attachments recommended or sold by the manufacturer. Doing otherwise may result in a risk of fire, electric shock, or injury to persons.
- Do not disassemble the charger. Attempting to service the unit yourself may result in a risk of electrical shock or fire. Internal capacitors remain charged after all power is disconnected.
- The charger must be provided with an equipment-grounding conductor connected to the AC input ground.
- To reduce the risk of electrical shock, disconnect both AC and DC power from the charger before attempting any maintenance or cleaning or working on any circuits connected to the charger. Turning off controls will not reduce this risk.
- Do not operate the charger if it has received a sharp blow, been dropped, or otherwise damaged in any way.
- To avoid a risk of fire and electric shock, make sure that existing wiring is in good condition and that wire is not undersized. Do not operate the charger with damaged or substandard wiring.

### Installation Location: Physical requirements for installation

Condition	Description
Clean	Do not expose the charger to metal filings or any other form of conductive contamination. The presence of conductive contamination can cause damage and void your warranty.
Cool	For best performance, the ambient air temperature should be between 5°F (-15°C) and 113°F (45°C)- the cooler the better. At higher ambient temperatures, the output current will be automatically reduced to protect the charger from high internal temperatures.
Dry	The unit is intended for use in a dry location. Do not allow water or other fluids to drip or splash on the charger. Do not mount the charger in an area subject to rain, spray or splashing bilge water.

Safe	This battery charger is Ignition Protected, so it can be installed in areas containing gasoline tanks or fittings which usually require Ignition Protected equipment. It is safest not to install electrical equipment in these areas.
Ventilated	Allow at least 4 inches (10 cm) of clearance around all sides of the charger for air flow. Ensure that the ventilation openings on the unit are not obstructed. If mounting in a compartment, ventilate the compartment with louvres or cut-outs to prevent overheating.
Close to AC junction box	Avoid the use of extended wire lengths if possible.
Close to batteries	Avoid excessive cable lengths and use the recommended wire lengths and sizes. Undersized or overly long cables may affect charging accuracy.

## Installation Illustration

• Before charging, read the instructions; for indoor use only. Disconnect the supply before making or breaking the connections to the battery.

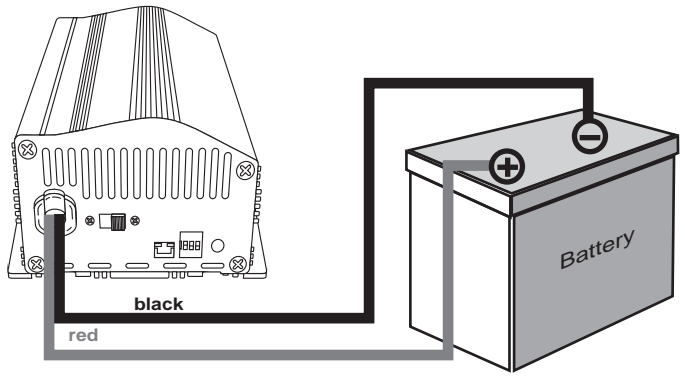

### WARNING

Explosive gases; Prevent flames and sparks; Provide adequate ventilation during charging. Include a warning against recharging non-rechargeable batteries. If the supply cord is damaged, it must be replaced by a special cord or assembly available from the manufacturer or it's service agent.

### Explosive gas precautions

1. The charger have been approved as Ignition Protected. They may be installed in areas containing gasoline tanks and fittings which require Ignition Protected equipment. It is safest not to install electrical equipment in these areas.
2. To reduce the risk of battery explosion, follow these instructions and those published by the battery manufacturer and the manufacturer of the equipment in which the battery is installed.
3. Working in the vicinity of lead-acid batteries is dangerous. Batteries generate explosive gases during normal operation. Therefore you must read this guide and follow the instructions exactly before installing or using your charger.

### Isolated Design

The DC battery charging circuits of this charger are galvanically isolated by a transformer from the AC power circuits. This feature reduces the risk of electric shock and helps to prevent corrosion problems in marine applications.

### Charging volt graph (0:OFF ■)

	Mode 1 (100)	Suitable for re-charging lead storage battery.	
	Mode 2 (120)	Suitable for re-charging gel battery.	
	Mode 3 (003)	Suitable for re-charging lead storage battery, <b><i>which is in good condition battery (no any sulfated situation), and completely disconnected from the devices it runs.</i></b> because this mode has the additional stage the battery may reach voltage too high for them, and the limited current delivered by the battery charger. This is not able to provide power for the devices, and simultaneously charge the battery.	
	Mode 4 (020)	Suitable for recovery of sulfated gel battery, i.e. discharged batteries unused for long periods or the battery that never re-charges completely. This mode should be applied with the battery completely disconnected from the devices it runs.	
	Mode 5 (023)	Suitable for recovery sulfated lead storage battery, i.e. discharged batteries unused for long periods or the battery that never re-charges completely. This mode should be applied with the battery completely disconnected from the devices it runs.	
	Mode 6 (123)	DC power supply. [12.2V (for 12V spec.) / 24.5V (for 24V spec.) ]	
	Mode 7 (000)	DC power supply. [13.5V (for 12V spec.) / 27V (for 24V spec.) ]	